

Splitters and Preamps for Driving Multiple Receivers in Series 7000 Direction Finders

A Technical Application Note from Doppler Systems

June 8, 2013

1.0 Introduction

Multiple DDF7000 direction finding processors can share a common antenna. A block diagram of two DDF7000 processors sharing one antenna is shown below.

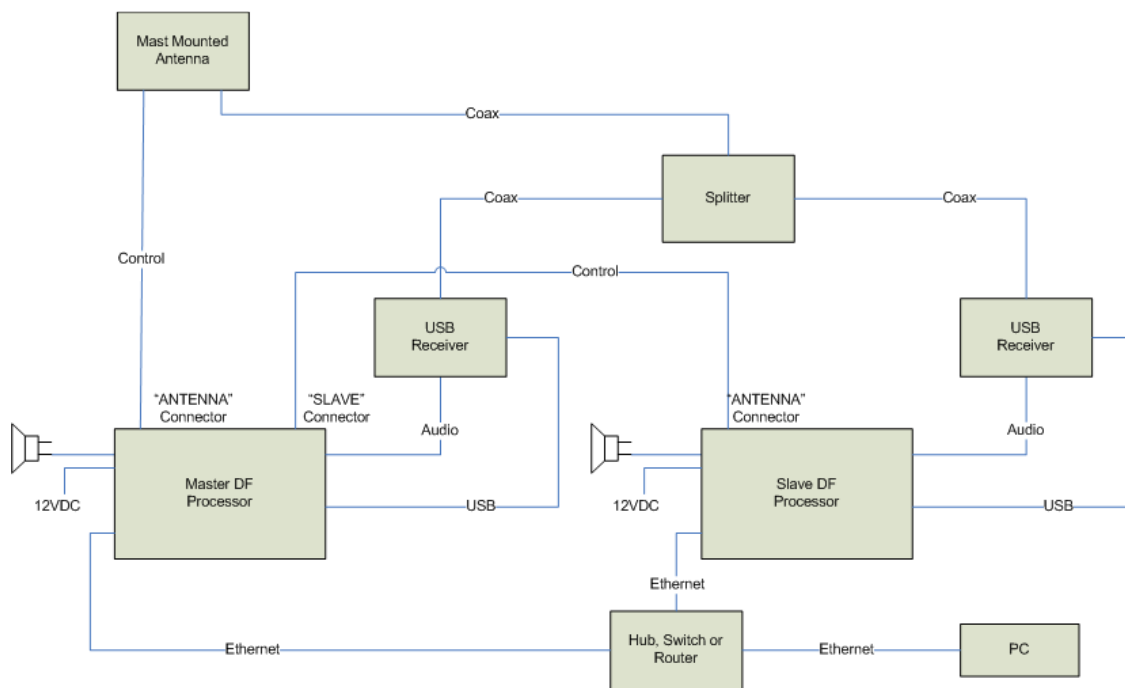

Figure 1 - Multiple Receivers on Single DF Antenna

To share a common antenna

- One DDF7000 processor must be configured as a master (DDF7001) and all other processors must be configured as slaves (DDF7002)
- You must have a receiver for each processor
- A splitter is required to route the RF signal from the antenna to each receiver.

This application note discusses the selection of the splitter and the effect it has on the sensitivity. The use of a preamplifier in the RF path between the antenna and the splitter is then analyzed. Although somewhat counterintuitive, it is demonstrated that

inclusion of a preamplifier can actually degrade overall performance by compromising the ability of the system to handle strong interference signals.

2.0 RF Splitters

The RF splitter (combiner) should be one of the 50 ohm inductive types with BNC connectors, low insertion loss, high isolation and a bandwidth covering the frequency range of interest. In this application the phase and amplitude unbalance are not important. Minicircuit Labs makes a range of these products that can be used. Typical models for 2, 3, 4, 8 and 16 way splitters are listed below.

Table 1 - Typical RF Splitters (Minicircuit Laboratories)

<i>Model</i>	<i>Type</i>	<i>Frequency Range (MHz)</i>	<i>Typical Isolation (dB)</i>	<i>Typical Insertion Loss (dB)</i>
ZFSC-2-5+	2-way, 0 deg	10 - 1500	30	3.5
ZFSC-3-4+	3-way, 0 deg	1 - 1000	20	5.6
ZFSC-4-1+	4-way, 0 deg	1 - 1000	23	6.6
ZFSC-8-43+	8-way, 0 deg	10 - 1000	25	10.4
ZFSC-16-12+	16-way, 0 deg	0.1 - 200	27	12.7

The insertion loss is simply a consequence of the power division. For example, an ideal 2 way splitter delivers half the input power (3 dB) to each output.

3.0 Direction Finder Dynamic Range

The dynamic range of the direction finder is determined by the characteristics of the RF summing electronics located in the antenna, those of the receiver and any losses in the cabling connecting the antenna to the receiver. The RF summing electronics generally dominate the calculation. When there is no interference, sensitivity is limited by the noise generated inside the electronics. When strong signals are present on adjacent frequencies, non-linearities inside the electronics can result in interference on the received frequency.

We can define the dynamic range of the summer as the difference between the input signal level in dBm which causes a compression of 1 dB at the output of the summer to the noise floor in dBm at the input. Note that while useful for this discussion, this definition is overly optimistic and overstates the usual dynamic range by about 10 dB (the signal to noise ratio required for a stable bearing). Both the input power level for 1 dB compression and the noise floor can be calculated from the gain, noise figure and output power at 1 dB compression of the RF circuits (preamplifiers, etc.)

The RF summer used in our current fixed site antennas has been characterized, and the measured results listed at the center frequencies of the VHF, UHF and THF bands are listed in the table below.

Table 2 - Performance of DDF6281 Rev F

Frequency (MHz)	Gain (dB)	NF (dB)	P1dB (dBm)	Noise Floor (dBm)	Input P1dB (dBm)	Linear Dynamic Range (dB)
177	6.50	4.29	8.5	-131	3.00	134
354	5.30	5.49	8.5	-129	4.20	133
707	5.05	5.74	8.5	-129	4.45	133

An improved RF Summer has been designed which has the calculated characteristics shown in Table 3.

Table 3 - Performance of DDF6281 Rev G

Frequency (MHz)	Gain (dB)	NF (dB)	P1dB (dBm)	Noise Floor (dBm)	Input P1dB (dBm)	Linear Dynamic Range (dB)
177	12.10	1.91	11.0	-136	-0.10	136
354	10.20	2.37	10.0	-135	0.80	135
707	10.16	2.38	10.86	-135	1.70	136

4.0 Cascaded RF Summer and Splitter

Figure 2 shows the connection of an RF summer to an N -way splitter which then distributes the antenna signal to N receivers.

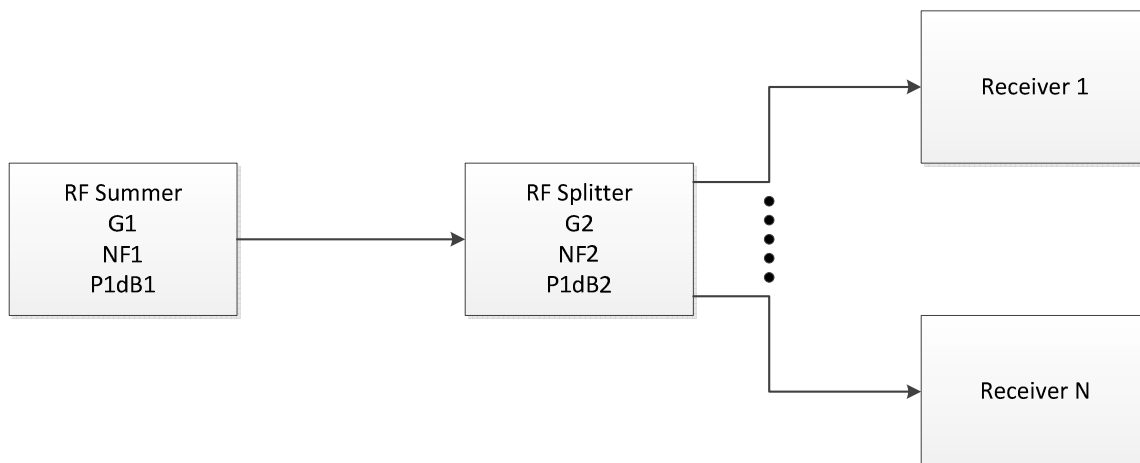

Figure 2 - Cascade of RF Summer and Splitter

The effect of the splitter is to increase the noise floor and thereby reduce the linear dynamic range. The overall gain, noise figure and 1dB compression power for the cascade can be found using, for example, the calculator [Cascade Calculator - Microwave](#)

Encyclopedia - Microwaves101.com. The results for the current RF summer with 4, 8 and 16 way splitters are listed in Tables 4 through 6 and are repeated for the new RF summer in Tables 7 through 9.

Table 4- Performance of DDF6281 Rev F with 4-way splitter

Frequency (MHz)	Gain (dB)	NF (dB)	P1dB (dBm)	Noise Floor (dBm)	Input P1dB (dBm)	Linear Dynamic Range (dB)
177	-0.50	5.54	1.5	-129	3.00	132
354	-1.70	6.74	1.5	-127	4.20	132
707	-1.95	6.99	1.5	-127	4.45	132

Table 5 – Performance of DDF6281 Rev F with 8-way splitter

Frequency (MHz)	Gain (dB)	NF (dB)	P1dB (dBm)	Noise Floor (dBm)	Input P1dB (dBm)	Linear Dynamic Range (dB)
177	-3.50	6.72	-1.5	-128	3.00	131
354	-4.70	7.92	-1.5	-126	4.20	130
707	-4.95	8.17	-1.5	-126	4.45	130

Table 6 - Performance of DDF6281 Rev F with 16-way splitter

Frequency (MHz)	Gain (dB)	NF (dB)	P1dB (dBm)	Noise Floor (dBm)	Input P1dB (dBm)	Linear Dynamic Range (dB)
177	-6.50	8.41	-4.5	-125	3.00	128
354	-7.70	9.61	-4.5	-124	4.20	128
707	-7.95	9.86	-4.5	-124	4.45	128

Table 7 - Performance of DDF6281 Rev G with 4-way splitter

Frequency (MHz)	Gain (dB)	NF (dB)	P1dB (dBm)	Noise Floor (dBm)	Input P1dB (dBm)	Linear Dynamic Range (dB)
177	5.10	2.55	4.0	-134	-0.1	134
354	3.20	3.24	3.0	-133	0.8	134
707	3.16	3.26	3.86	-133	1.7	134

Table 8 - Performance of DDF6281 Rev G with 8-way splitter

Frequency (MHz)	Gain (dB)	NF (dB)	P1dB (dBm)	Noise Floor (dBm)	Input P1dB (dBm)	Linear Dynamic Range (dB)
177	2.10	3.24	1.0	-133	-0.1	133
354	0.20	4.13	0	-131	0.8	132
707	0.16	4.15	0.86	-131	1.7	133

Table 9 - Performance of DDF6281 Rev G with 16-way splitter

Frequency (MHz)	Gain (dB)	NF (dB)	P1dB (dBm)	Noise Floor (dBm)	Input P1dB (dBm)	Linear Dynamic Range (dB)
177	-0.90	4.35	-2.0	-131	-0.1	131
354	-2.80	5.48	-3.0	-129	0.8	130
707	-2.84	5.51	-2.14	-129	1.7	131

Comparing these results to the performance without the splitters in Tables 2 and 3, we can see that the effect of the 4 way splitter is to reduce the linear dynamic range by about 1.5dB, the effect of the 8 way splitter is to reduce the linear dynamic range by about 3 dB and the effect of the 16 way splitter is to reduce the linear dynamic range by about 5 dB.

5.0 Cascaded RF Summer, Preamp and Splitter

A perfect preamp (possessing infinite gain, no internally generated noise, and perfect linearity at arbitrary output power) will compensate for the loss through the splitter and restore the linear dynamic range to that of the RF summer alone.

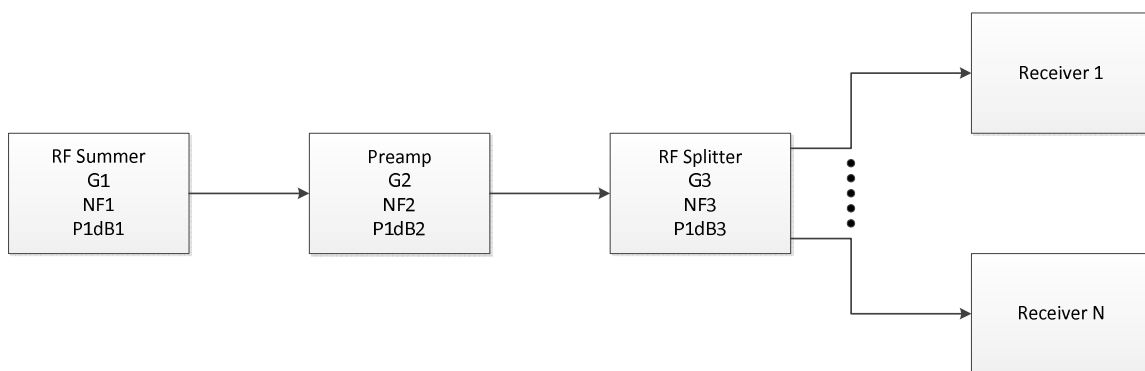

Figure 3 - Cascade of RF Summer, Preamp and Splitter

A real preamp will reduce the noise floor somewhat but it will also reduce the input signal level that results in 1 dB compression. Rather than evaluate the performance for a series of candidate preamps, we can determine what characteristics a preamp should have to result in a noise floor that is within 0.5 dB of the RF summer alone, and also

result in an input signal for 1 dB compression that is within 0.5 dB of the RF summer alone. Stated differently, we answer the question as to what are the preamp characteristics that will restore the linear dynamic range to within 1 dB of what the RF summer provided before the splitter was added?

The answer to this question requires an iterative calculation in which one of the preamp characteristics (the gain G_2) is varied, and the required preamp noise figure NF_2 and compression output P_{1dB2} are computed for each value of the gain. This results in a series of curves which represent the requirements for the preamplifier.

Figures 4 through 6 show these requirements for a hypothetical preamp when used with the current RF summer while Figures 7 through 9 show the same requirements for the new RF summer.

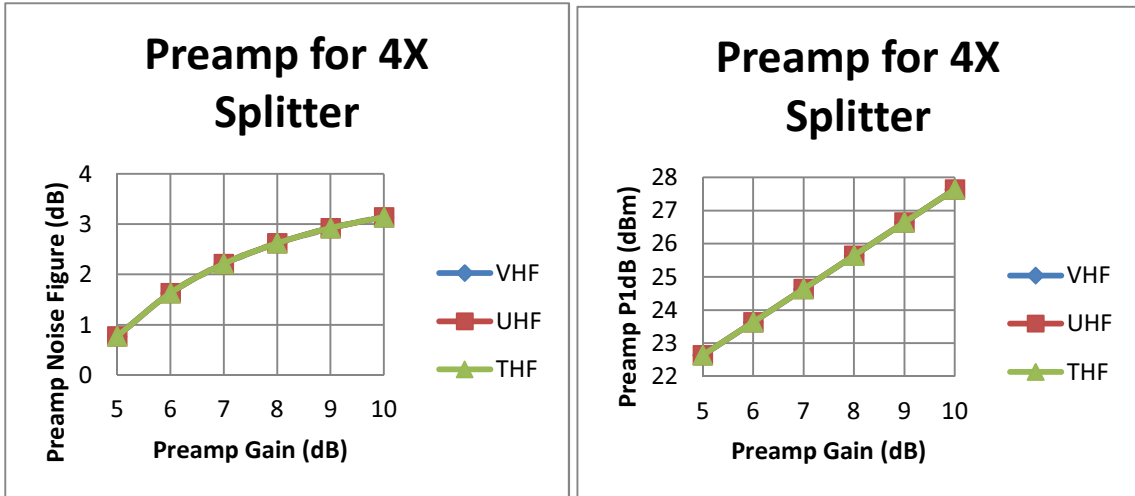

Figure 4 – Preamp requirements for DDF6281 Rev F summer with 4x splitter

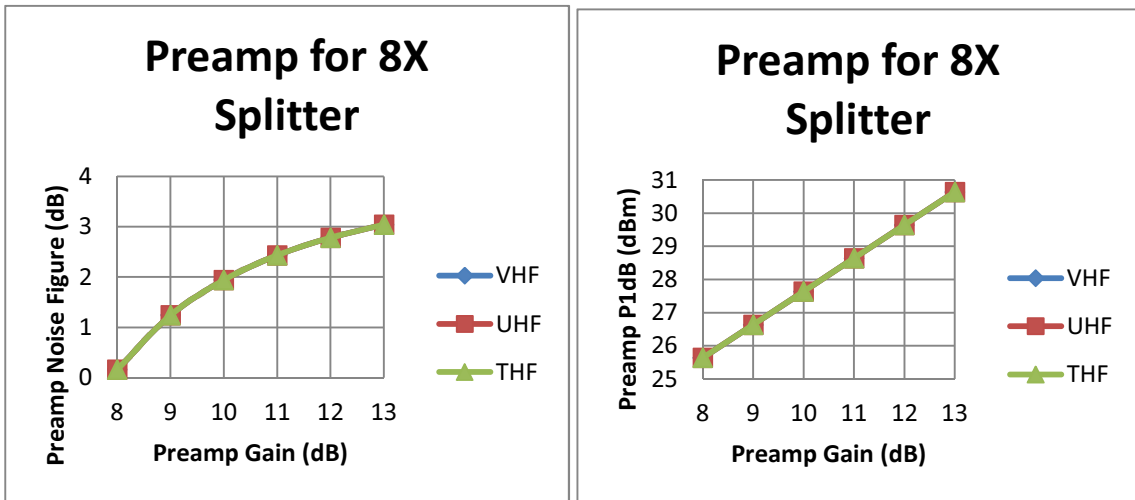

Figure 5 – Preamp requirements for DDF6281 Rev F summer with 8x splitter

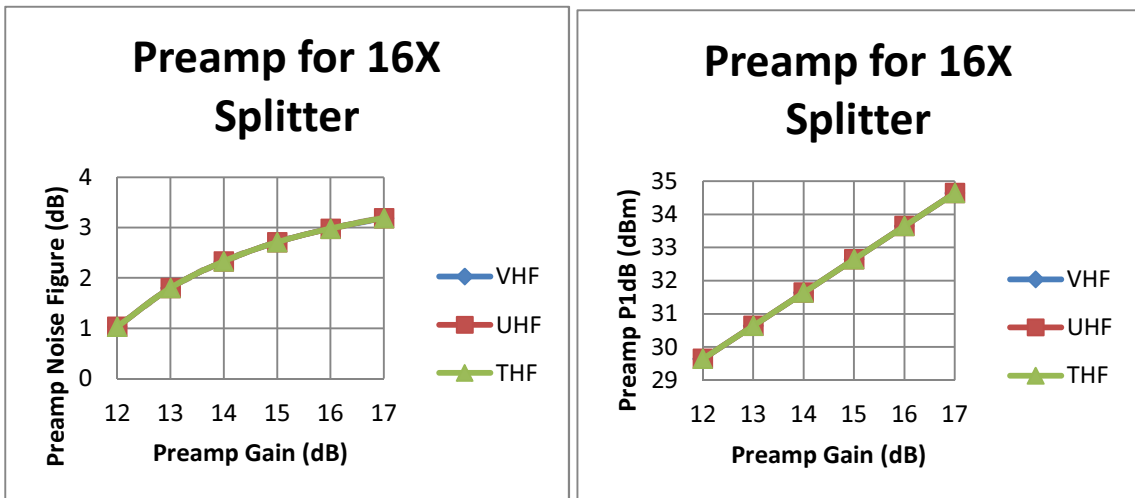

Figure 6 – Preamp requirements for DDF6281 Rev F summer with 16x splitter

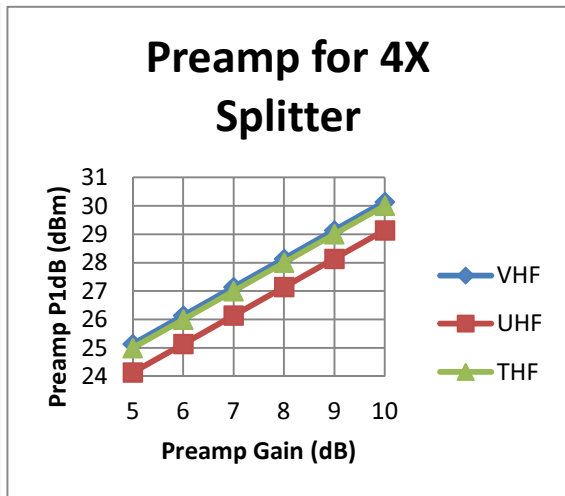
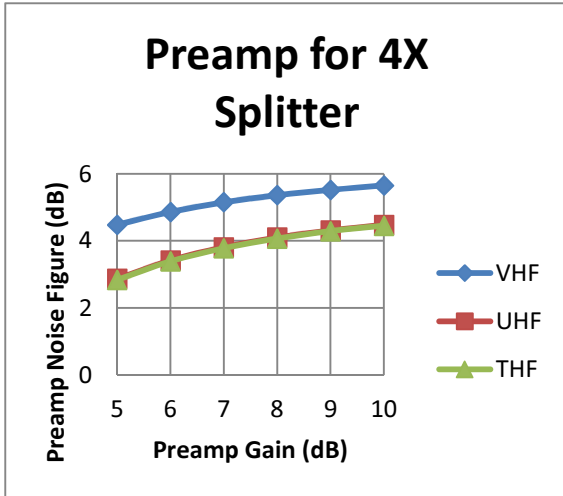

Figure 7 – Preamp requirements for DDF6281 Rev G summer with 4x splitter

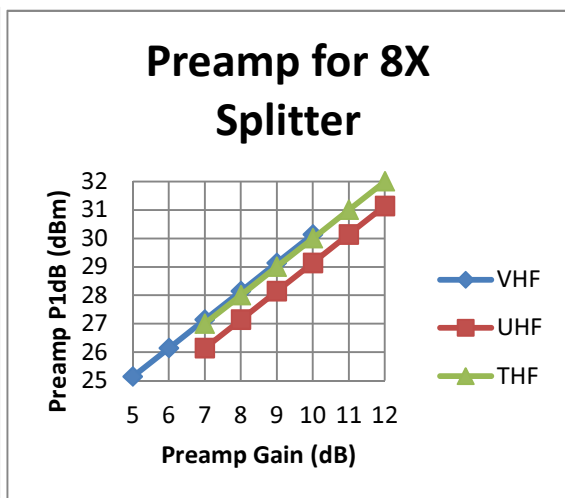
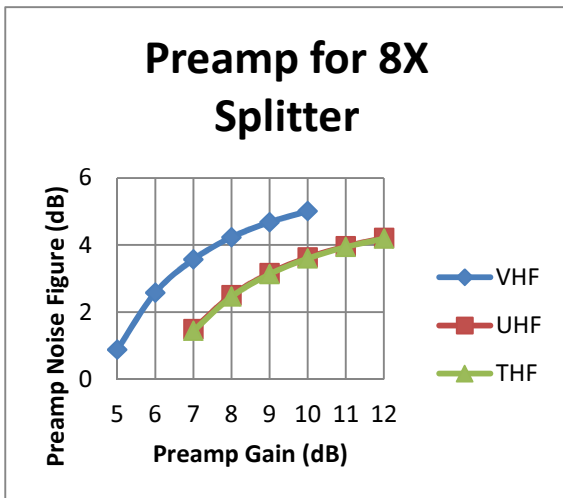

Figure 8 – Preamp requirements for DDF6281 Rev G summer with 8x splitter

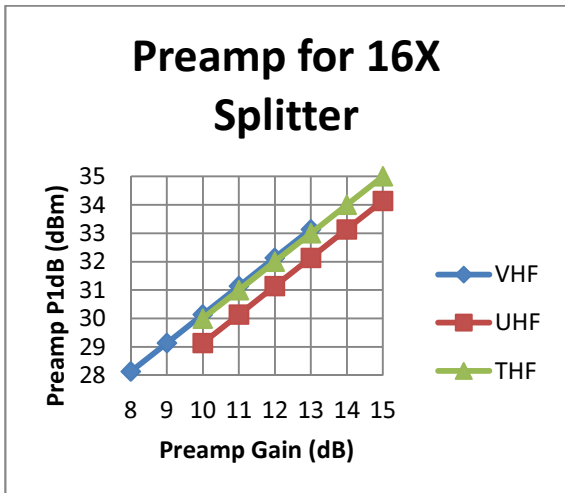
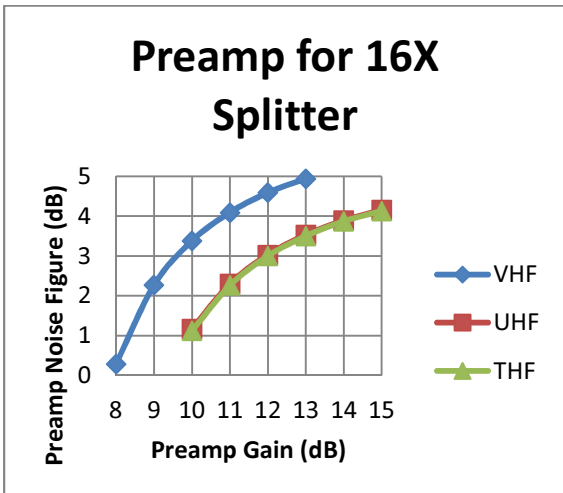

Figure 9 – Preamp requirements for DDF6281 Rev G summer with 16x splitter

6.0 Conclusions

For the 4 way splitter (4 receivers) there is little to be gained by inserting a preamp between the RF summer and the splitter because the addition of the splitter only reduces the dynamic range by 1.5 dB.

Similarly when an 8 way splitter is used, the loss in dynamic range is only 3 dB and not all of it can be recovered by adding a preamp.

For a 16 way splitter, up to 5 dB is lost, so the incentive for finding a suitable preamp is greater. However, the requirements are daunting. As shown in Figures 6 and 9, the preamp needs to have a 1 dB compression output greater than 30 dBm (1 watt). Most wide band preamps have lower P1dB and higher gains than are needed for this application. As shown in the graphs, the higher gain is undesirable as it requires even higher P1dB. One device that comes reasonably close to satisfying all of these requirements is the Minicircuit Labs ZHL-1010+.

Table 10 – Performance of ZHL-1010+ Preamplifier

<i>Model</i>	<i>Frequency Range (MHz)</i>	<i>Gain (dB)</i>	<i>NF (dB)</i>	<i>P1dB (dBm)</i>
ZHL-1010+	50 - 1000	9.5	3.5	26

Using these parameters in the cascade calculation, we obtain the following for the overall performance of the Rev G summer, preamp and splitter:

Table 11 - Performance of DDF6281 Rev G, ZHL-1010+ and 16 way splitter

Frequency (MHz)	Gain (dB)	NF (dB)	P1dB (dBm)	Noise Floor (dBm)	Input P1dB (dBm)	Linear Dynamic Range (dB)
177	8.6	2.45	6.42	-134.4	-1.2	133.2
354	6.7	3.11	5.62	-133.0	-0.1	132.9
707	6.66	3.13	6.31	-133.0	0.7	133.7

Comparing the results from Tables 3, 9 and 11 we see that this preamp recovered only about half of the 5 dB lost in the linear dynamic range by the 16 way splitter attenuation.

Table 12 - Comparison of Linear Dynamic Range

Frequency (MHz)	DDF6281G only	DDF6281G + 16 way splitter	DDF6281G + Preamp + 16 way splitter
177	136	131	133
354	135	130	133
707	136	131	134

Significant effort went into the design of the RF summers used in the Series 7000 radio direction finders because they are inherently wide band and must work in an environment that contains a wide dynamic range of signals. Adding a splitter at the output of this summer reduces the sensitivity and hence the linear dynamic range by only a few dB. Great care must be taken when selecting a preamp to recover this loss in dynamic range. It is relatively easy to find a preamp that compensates for the attenuation inherent in the splitter, but very difficult to find one that does not also compromise the strong signal handling capability.